













































































































4.3.7 Digital I/Os

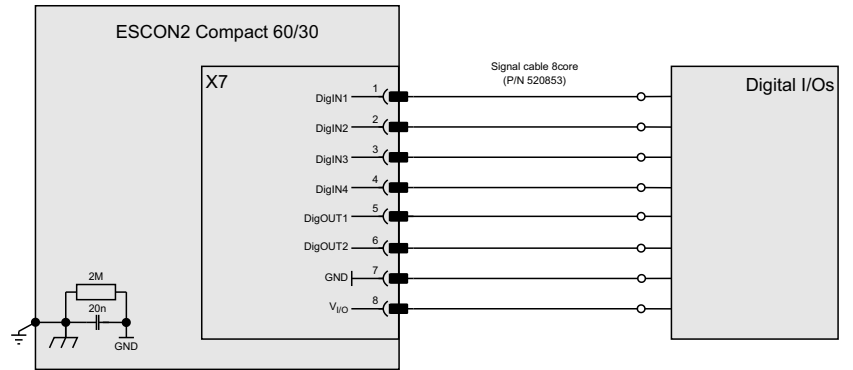

Figure 4-52 Digital I/Os

4.3.8 Analog I/Os

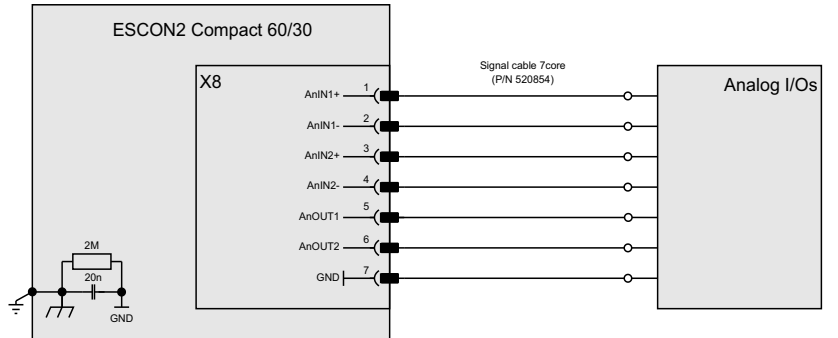

Figure 4-53 Analog I/Os

4.3.9 CAN

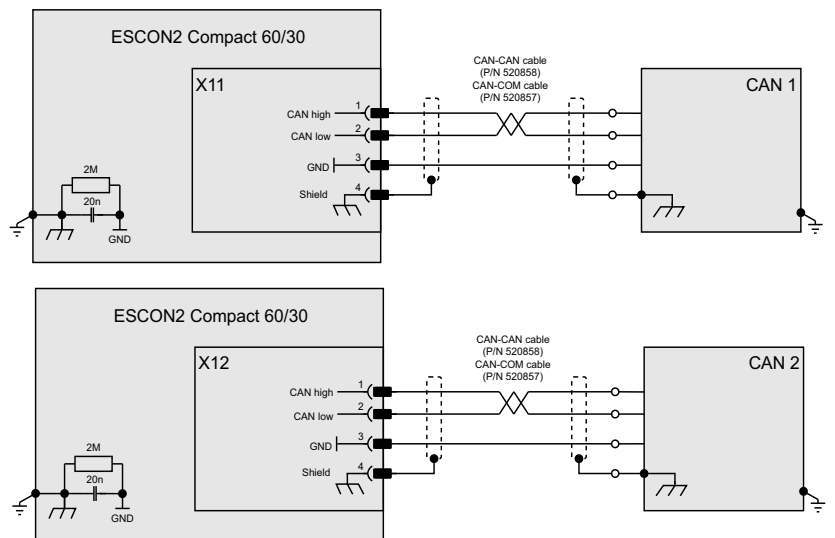

Figure 4-54 CAN

Depending on the preferred interface, one of the two prefab CAN cables can be used.

### 4.3.10 USB

#### 4.3.10.1 USB-C

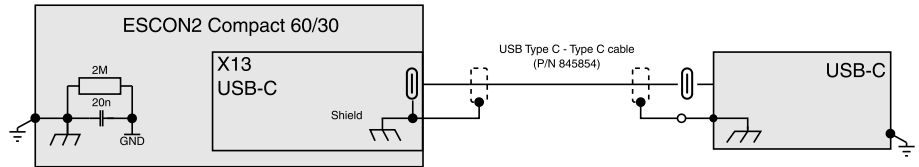

Figure 4-55 USB-C

#### 4.3.10.2 USB-A

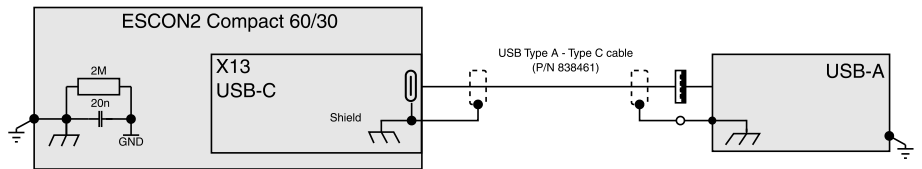

Figure 4-56 USB-A

### 4.3.11 Motor temperature sensor (future release)

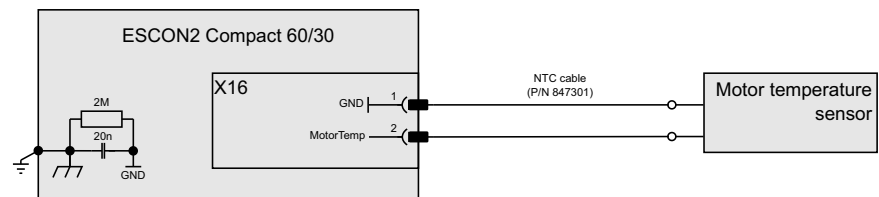

Figure 4-57 Motor temperature sensor

## LIST OF FIGURES

Figure 1-1	Documentation structure . . . . .	5
Figure 2-2	Derating of output current (operation without additional heatsink) . . . . .	11
Figure 2-3	Extended operation @ VCC 60 VDC with additional heatsink . . . . .	12
Figure 2-4	Power dissipation and efficiency . . . . .	12
Figure 2-5	Dimensional drawing [mm] . . . . .	14
Figure 2-6	Dimensional drawing – Attachment points [mm] . . . . .	14
Figure 3-7	Connections . . . . .	18
Figure 3-8	Power supply connector X1 . . . . .	20
Figure 3-9	Logic supply connector X2 . . . . .	22
Figure 3-10	Motor connector X3a . . . . .	22
Figure 3-11	Motor connector X3b . . . . .	23
Figure 3-12	Sensor 1 Hall sensor connector X4 . . . . .	25
Figure 3-13	Sensor 1 Hall sensor input circuit (analogously valid for Hall sensors 2 & 3) . . . . .	26
Figure 3-14	Sensor 2 connector X5 . . . . .	26
Figure 3-15	Digital incremental encoder input circuit Ch A “differential” (analogously valid for Ch B) . . . . .	28
Figure 3-16	Digital incremental encoder input circuit Ch A “single-ended” (analogously valid for Ch B) . . . . .	29
Figure 3-17	SSI absolute encoder data input (analogously valid for BiSS C) . . . . .	30
Figure 3-18	SSI absolute encoder clock output (analogously valid for BiSS C) . . . . .	30
Figure 3-19	HsDigIN1 circuit “differential” (analogously valid for HsDigIN2) . . . . .	31
Figure 3-20	HsDigIN1 circuit “single-ended” (analogously valid for HsDigIN2...3) . . . . .	32
Figure 3-21	HsDigIN4 circuit “single-ended” . . . . .	33
Figure 3-22	Wiring examples for proximity sensors and switches on HsDigIN1 (analogously valid for HsDigIN2) . . . . .	33
Figure 3-23	HsDigOUT1 circuit . . . . .	34
Figure 3-24	Wiring examples for “sourcing” on HsDigOUT1 . . . . .	34
Figure 3-25	Digital I/Os connector X7 . . . . .	34
Figure 3-26	DigIN1 circuit (analogously valid for DigIN2) . . . . .	36
Figure 3-27	DigIN3 circuit (analogously valid for DigIN4) . . . . .	36
Figure 3-28	Wiring examples for proximity sensors and switches on DigIN1 (analogously valid for DigIN2..4) . . . . .	37
Figure 3-29	DigOUT1 circuit with wiring example for “sinking” inductive loads (analogously valid for DigOUT2) . . . . .	37
Figure 3-30	DigOUT1 circuit with wiring examples for “sinking” general-purpose loads (also valid for DigOUT2) . . . . .	38
Figure 3-31	DigOUT1 circuit with wiring examples for “sourcing” (analogously valid for DigOUT2) . . . . .	38
Figure 3-32	Analog I/Os connector X8 . . . . .	39
Figure 3-33	AnIN1 circuit (analogously valid for AnIN2) . . . . .	40
Figure 3-34	Wiring examples for a potentiometer on AnIN1 (analogously valid for AnIN2) . . . . .	40
Figure 3-35	AnOUT1 circuit (analogously valid for AnOUT2) . . . . .	41
Figure 3-36	CAN 1 connector X11/CAN 2 connector X12 . . . . .	41
Figure 3-37	USB connector X13 . . . . .	42
Figure 3-38	Motor temperature sensor connector X16 . . . . .	43
Figure 3-39	Motor temperature circuit . . . . .	44
Figure 3-40	DIP switch SW1 . . . . .	45
Figure 3-41	LEDs – Location . . . . .	48

Figure 4-42	Interfaces – Designations and location . . . . .	49
Figure 4-43	Main wiring diagram . . . . .	51
Figure 4-44	Power supply . . . . .	52
Figure 4-45	Logic supply . . . . .	52
Figure 4-46	DC motor . . . . .	52
Figure 4-47	EC (BLDC) motor . . . . .	53
Figure 4-48	Sensor 1 Hall sensor . . . . .	53
Figure 4-49	Digital incremental encoder . . . . .	53
Figure 4-50	SSI / BiSS C unidirectional absolute encoder . . . . .	54
Figure 4-51	High-speed digital I/Os . . . . .	54
Figure 4-52	Digital I/Os . . . . .	55
Figure 4-53	Analog I/Os . . . . .	55
Figure 4-54	CAN . . . . .	55
Figure 4-55	USB-C . . . . .	56
Figure 4-56	USB-A . . . . .	56
Figure 4-57	Motor temperature sensor . . . . .	56

## LIST OF TABLES

Table 1-1	Notations used in this document . . . . .	6
Table 1-2	Symbols and signs . . . . .	6
Table 1-3	Sources for additional information. . . . .	7
Table 2-4	Technical data . . . . .	10
Table 2-5	Heatsink – tested components . . . . .	12
Table 2-6	Limitations . . . . .	13
Table 2-7	Standards . . . . .	15
Table 3-8	Prefab maxon cables. . . . .	19
Table 3-9	Motion connector set highest current – Content . . . . .	19
Table 3-10	Recommended tools . . . . .	20
Table 3-11	Power supply connector X1 – Pin assignment . . . . .	20
Table 3-12	Power cable highest current . . . . .	21
Table 3-13	Power supply requirements. . . . .	21
Table 3-14	Logic supply connector X2 – Pin assignment . . . . .	22
Table 3-15	Power cable. . . . .	22
Table 3-16	Logic supply requirements . . . . .	22
Table 3-17	Motor connector X3a – Pin assignment for maxon EC & DC motor . . . . .	23
Table 3-18	Motor cable highest current. . . . .	23
Table 3-19	Motor connector X3b – Pin assignment for maxon EC & DC motor . . . . .	24
Table 3-20	Motor cable high current . . . . .	24
Table 3-21	Sensor 1 Hall sensor connector X4 – Pin assignment . . . . .	25
Table 3-22	Sensor 1 Hall sensor cable . . . . .	25
Table 3-23	Sensor 1 Hall sensor specification . . . . .	26
Table 3-24	Sensor 2 connector X5 – Pin assignment. . . . .	27
Table 3-25	Encoder cable . . . . .	27
Table 3-26	Differential digital incremental encoder specification . . . . .	28
Table 3-27	Single-ended digital incremental encoder specification . . . . .	28
Table 3-28	SSI / BISS C unidirectional absolute encoder specification . . . . .	29
Table 3-29	Single-ended SSI / BISS C unidirectional absolute encoder data channel specification . . . . .	29
Table 3-30	Single-ended SSI / BISS C unidirectional absolute encoder clock channel specification . . . . .	30
Table 3-31	Encoder cable . . . . .	31
Table 3-32	Differential high-speed digital inputs specification. . . . .	31
Table 3-33	Single-ended high-speed digital input specification . . . . .	32
Table 3-34	High-speed digital output specification . . . . .	33
Table 3-35	Digital I/Os connector X7 – Pin assignment . . . . .	35
Table 3-36	Signal cable 8core. . . . .	35
Table 3-37	Digital inputs 1...2 specification . . . . .	35
Table 3-38	Digital inputs 3...4 specification . . . . .	36
Table 3-39	Digital outputs specification – Sinking. . . . .	37
Table 3-40	Digital outputs specification – Sourcing. . . . .	38
Table 3-41	Analog I/Os connector X8 – Pin assignment. . . . .	39

Table 3-42	Signal cable 7core . . . . .	39
Table 3-43	Analog input specification . . . . .	39
Table 3-44	Analog output specification . . . . .	40
Table 3-45	CAN 1 connector X11/CAN 2 connector X12 – Pin assignment . . . . .	41
Table 3-46	CAN-CAN cable . . . . .	41
Table 3-47	CAN-COM cable . . . . .	42
Table 3-48	CAN interface specification . . . . .	42
Table 3-49	USB Type C – Type C cable . . . . .	43
Table 3-50	USB Type A – Type C cable . . . . .	43
Table 3-51	USB interface specification . . . . .	43
Table 3-52	Motor temperature sensor connector X16 – Pin assignment . . . . .	44
Table 3-53	NTC cable . . . . .	44
Table 3-54	Motor temperature sensor – specifications . . . . .	44
Table 3-55	DIP switch SW1 – Binary code values . . . . .	45
Table 3-56	DIP switch SW1 – Examples . . . . .	46
Table 3-57	DIP switch SW1 – CAN automatic bit rate detection . . . . .	47
Table 3-58	DIP switch SW1 – CAN bus termination . . . . .	47
Table 3-59	Device status LEDs . . . . .	48
Table 4-60	Possible combinations of feedback signals for DC motor . . . . .	50
Table 4-61	Possible combinations of feedback signals for EC (BLDC) motor . . . . .	50

## INDEX

### A

- alerts 6
  - CAUTION 6
  - DANGER 6
  - WARNING 6
- analog
  - inputs 39
  - outputs 40

### B

- BiSS C 29
- BiSS C unidirectional absolute encoder 30
- bit rate
  - CAN 42
  - default 42
  - detection 47

### C

- cables (prefab)
  - CAN-CAN cable 41
  - CAN-COM cable 42
  - Encoder cable 27, 31
  - Hall sensor cable 25
  - Motor cable high current 24
  - Motor cable highest current 23
  - NTC cable 44
  - Power cable 22
  - Power cable highest current 21
  - Signal cable 7core 39
  - Signal cable 8core 35
  - USB Type A - Type C cable 43
  - USB Type C - Type C cable 43

### CAN

- bit rate 42
- bus termination 42, 47
- ID (see "ID")
- interface 42
- choke, motor 9
- codes (used in this document) 6
- connections 18
- connector set 19
- connectors
  - X1 20
  - X11 41
  - X12 41
  - X13 42
  - X16 43
  - X2 22
  - X3 22
  - X3a 22, 23
  - X3b 23, 24
  - X4 25
  - X5 26
  - X7 34
  - X8 39
- country-specific regulations 8

### D

- digital
  - inputs 35, 36
  - outputs 37, 38
- digital high-speed
  - inputs (differential) 31
  - inputs (single-ended) 32
  - output 33
- digital incremental encoder
  - (differential) 28
  - (single-ended) 28
- DIP switch SW1 45
- directive EU, applicable 17

### E

- encoders
  - absolute 29
  - incremental 28
  - single-ended 29
  - SSI / BiSS C unidirectional absolute encoder 29
- ESD 8
- EU directive, applicable 17

### H

- Hall sensor 25, 26
- high-speed digital
  - inputs (differential) 31
  - inputs (single-ended) 32
  - output 33
- how to
  - calculate the required supply voltage 21
  - interpret icons (and signs) used in this document 6

### I

- ID (of the device) 45
- incorporation into surrounding system 17
- Incremental encoder 28
- informatory signs 6
- inputs
  - (differential) 31
  - (single-ended) 32
  - analog 39
  - digital 35, 36
  - high-speed digital 31
- interfaces
  - CAN 1 41
  - CAN 2 41
  - designation and location 49
  - USB 42, 43
- internal motor chokes 9

### L

- LED 48

### M

- mandatory action signs 6

motion connector set highest current 19  
motor choke 9  
motor connection 22  
motor temperature sensor 43

## **N**

Node-ID (see "ID")  
notations (used in this document) 6

## **O**

outputs  
    analog 40  
    digital 37, 38  
    high-speed digital 33

## **P**

part numbers  
    275829 22  
    275878 25  
    275934 27, 31  
    520851 24, 52, 53  
    520853 35  
    520854 39  
    520857 42  
    520858 41  
    783734 9  
    838459 21  
    838460 23, 52, 53  
    838461 43  
    845854 43  
    846645 19  
    847301 44  
performance data 9  
pin assignment 18, 20  
power supply 20  
precautions 8  
prerequisites prior installation 17  
prohibitive signs 6  
purpose  
    of the device 7  
    of the document 5

## **S**

safety alerts 6  
safety first! 8  
serial encoder 29  
signs used 6  
SSI 29  
SSI absolute encoder 30  
standards, fulfilled 15  
status LEDs 48  
supply voltage, required 21  
SW1 45  
symbols used 6

## **T**

technical data 9  
termination (CAN bus) 42, 47

## **U**

USB 42

## **W**

wiring examples  
    analog I/Os 55  
    CAN 55  
    DC motor 52, 53  
    digital I/Os 55  
    digital incremental encoder 53  
    high-speed digital I/Os 54  
    logic supply 52  
    motor temperature sensor 56  
    power supply 52  
    sensor 1 hall sensor 53  
    sensor 2 encoder I/Os 53  
    SSI / BiSS C unidirectional absolute encoder 54  
    USB-A 56  
    USB-C 56

••page intentionally left blank••

